

RC Designs

HUB-1.5 for communication cabinets

Prepared for NYCT • Mar 2016

1. Purpose

The HUB will be permanently installed on the top of the cabinet with double layer ceiling . Installation of the HUB will require drilling of 2" dia central hole from the inside and two side holes for the flange screws. It will be water tight via the O - ring. It will be NEMA compliant considering the metal to metal contact. For better protection of electrical and / or optical cables a plastic liner is inserted into the bore of the hub. In addition, in order to achieve better grounding of the HUB to the frame ground of the cabinet, a lock nut will be used inside of the cabinet (see picture shown below). The HUB is powder coated for scratch resistance. This HUB is IP68 compliant, tested for 6 hours under 1 inch of water.

2. Product

2.1. Material

List of Parts:

1. Steel HUB
2. Plastic liner inside the HUB
3. O-ring
4. Ground locking nut with spacer
5. Self-threaded screws with steel-rubber washers
6. Protective caps for exposed screws



Part number:

RCD-1.5-ST-UNV

Designed and manufactured in America

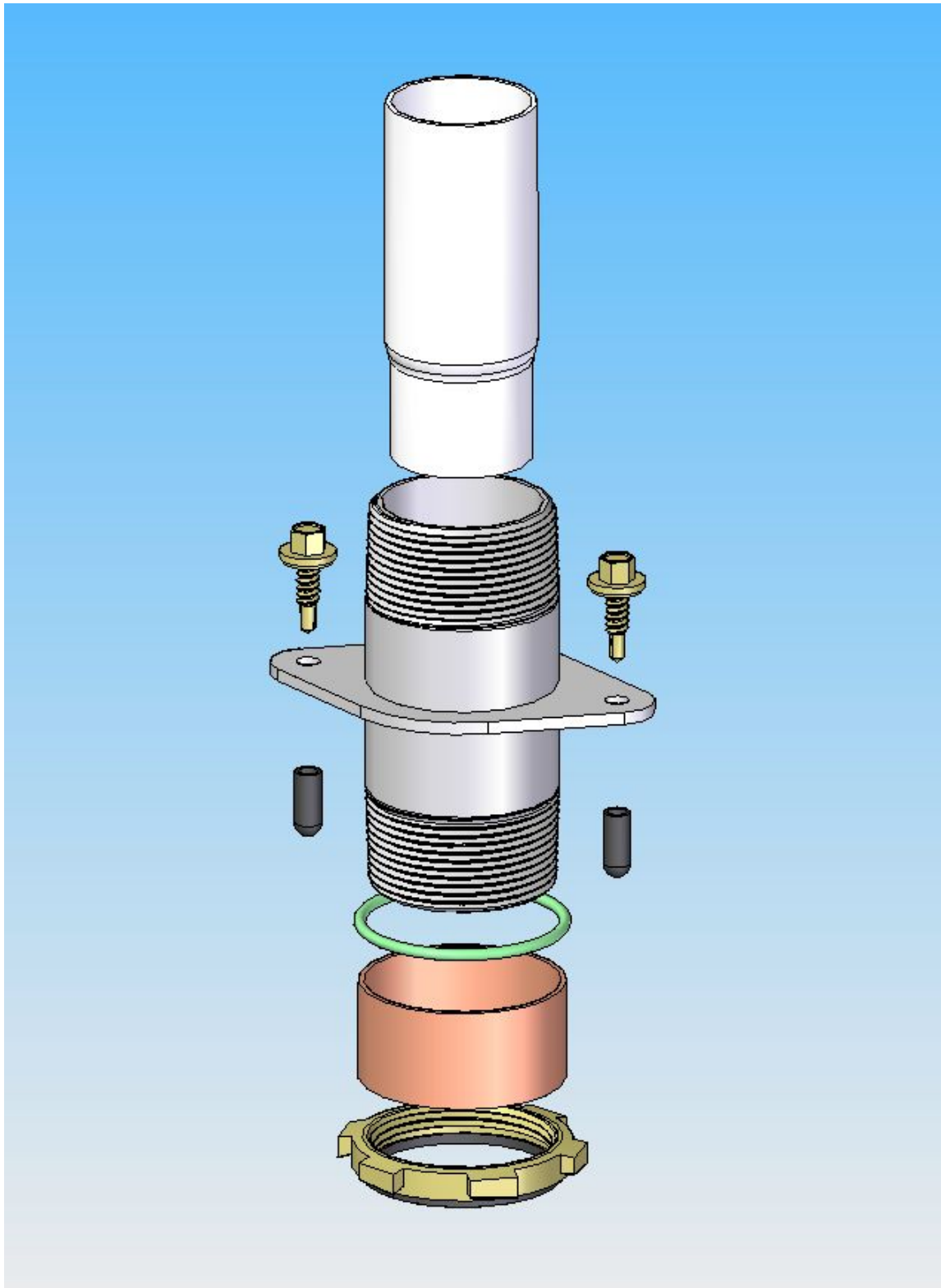

Patent Pending USPTO - 29561522-5705

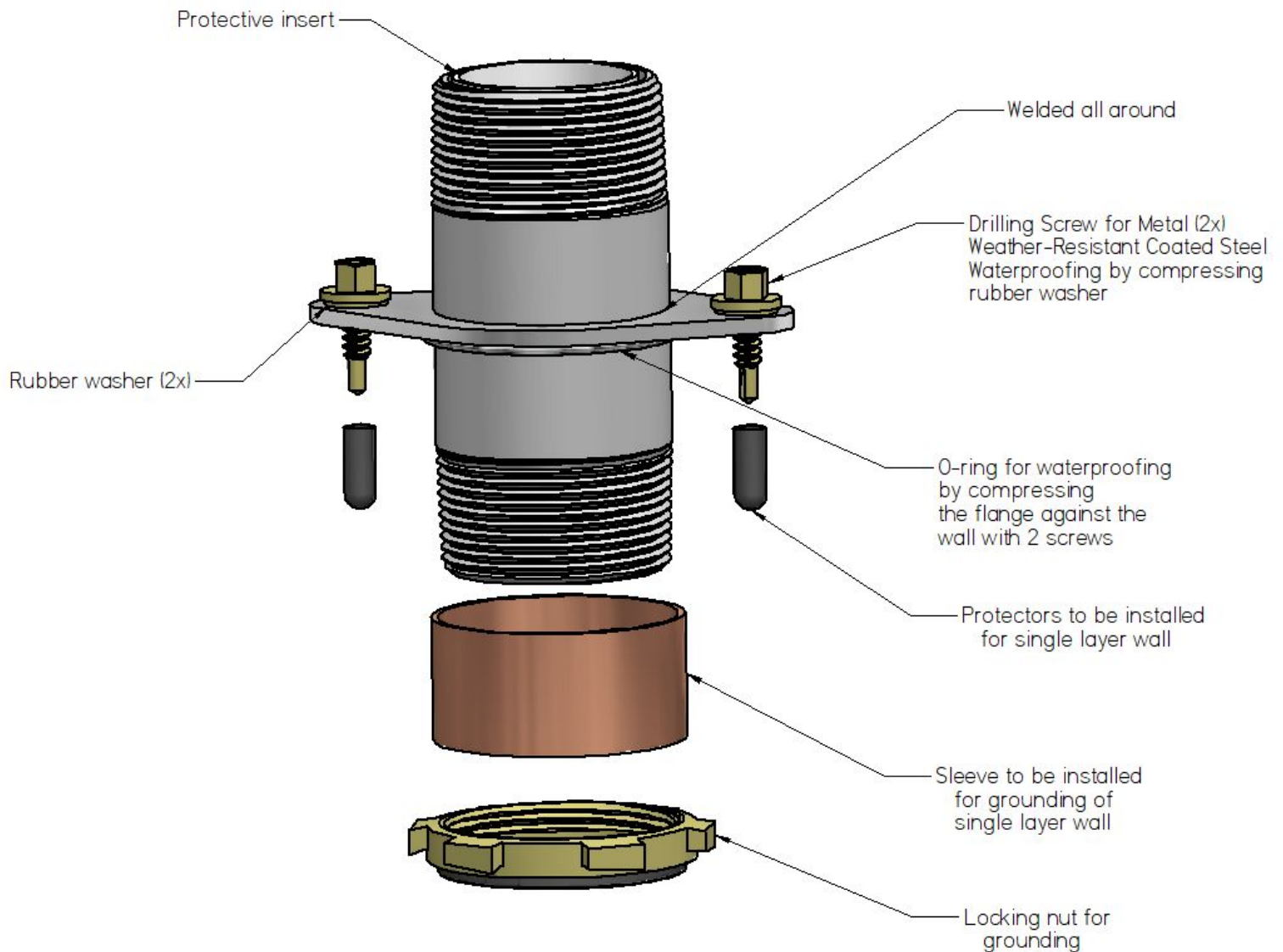

2.2. Installation

1. Drill through the large hole 2" dia from inside make sure that the pilot will mark the second ceiling.
2. Use $\frac{3}{4}$ HOLE Doser to drill second ceiling.
3. Clean the hole with Deburring Tool (not provided)
4. Place the extractor on the top of the cabinet and tight the male part of it on the inside.
5. Extract the hole by pumping the hydraulic
6. Remove the ground nut from the bottom of the flange
7. Place the HUB into the hole
8. Use the supplied self-threaded screws to secure the HUB on place
9. Use the locking nut only for additional bounding to the cabinet frame ground.

Screws dimensions

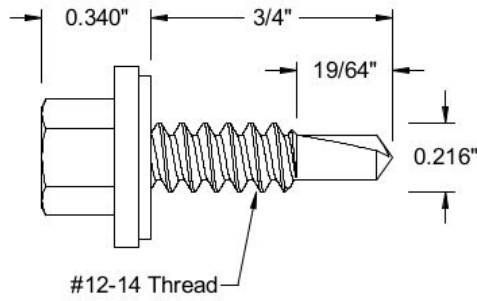
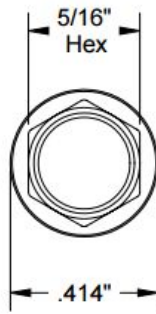

O-ring dimensions

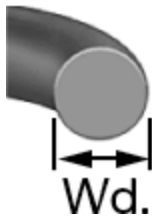

Actual Width
 0.103
 Fractional Size
 ID 1 7/8
 OD 2 1/16
 Actual Inch Size
 ID 1.862"
 OD 2.068

Sleeve dimensions

Inside diameter 2"
 Outside diameter 2 1/8"

Threaded steel pipe dimensions

Inside diameter 1.5"
 Outside diameter 1.935"
 Length 4"
 Width of the flange 4"